



PENNSYLVANIA INSERT
 PO BOX 199
 SPRING CITY, PA 19475
 P. 610.948.9688
 F. 610.948.9750

12/9/01

**WATERTIGHT JOINT FORMING
 SHIPLAP PALLETS**

YOU CAN FIND THIS INFORMATION ONLINE AT: PENNSYLVANIAINSERT.COM
 OR EMAIL YOUR REQUEST TO: SALES@PENNSYLVANIAINSERT.COM

DATE: _____ CUSTOMER: _____
 REV 1: _____ JOB: _____
 REV 2: _____ OWNER: _____

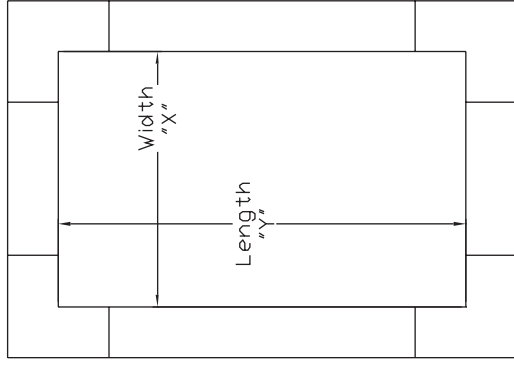
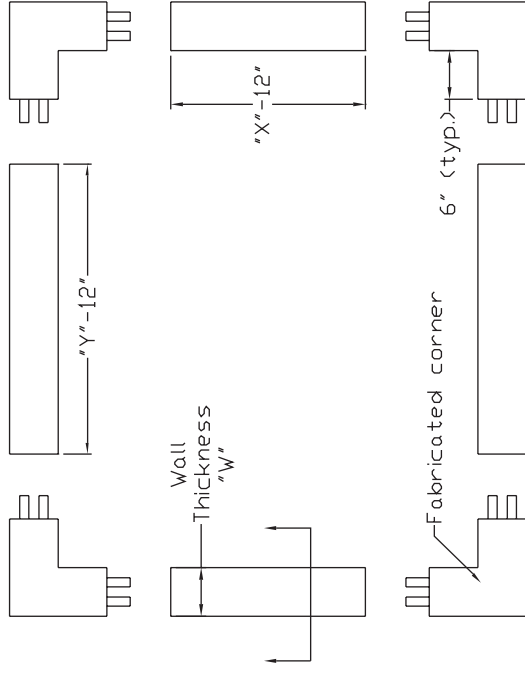
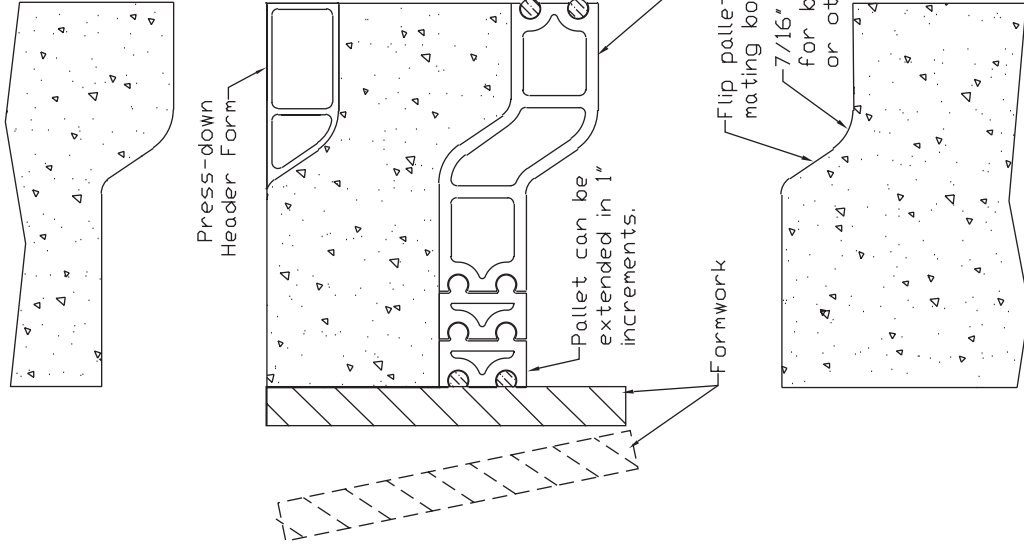

FOR PRE-ASSEMBLED PALLETS, PLEASE SPECIFY	
X	
Y	
W	
Header?	Y/N

FOR PARTS ONLY, PLEASE SPECIFY	
4" Pallet	ft.
6" Pallet	ft.
1" Ext.	ft.
Header	ft.
Gasket	ft.
Corners	ea.

SPECIFICATIONS:
 Watertight concrete manhole joint shall be formed by an aluminum shiplap pallet as manufactured by Pennsylvania Insert Corp., Spring City, PA. Pallet shall be extruded with dual integral gaskets to prevent concrete from leaking between the pallet and the core or wall of the formwork. Pallet shall be easily disassembled and stored and shall break down into straight lengths and connectable corners. The pallet shall be reversible to pour both tops and bottoms of monolithic precast concrete structures. The formed concrete joint shall feature an 7/16" annular void for bitumastic or other water stopping gasket. Pallets can be supplied with matching 'push-down' header form for manufacturing barrel sections.